

CONSEW®

CONSOLIDATED SEWING MACHINE CORPORATION
131 WEST 25TH STREET, NEW YORK, NY 10001

MODEL
315R-2

CSMP

INSTRUCTION & PARTS MANUAL

※NOTE (Fig. 1)

Before putting a new machine into operation, run-in operation is required for a new machine. Remove the rubber plug (A) on the top of arm, replenish sufficient amount of oil, then lift the presser foot and run the machine at a low speed of 2000 spm to check oil distributing condition through oil check window. When lubricating is normal, keep the machine run in at this speed for 30 minutes, then increase the running speed gradually, after one month run-in operation, the machine can be run at the Max speed under normal working condition.

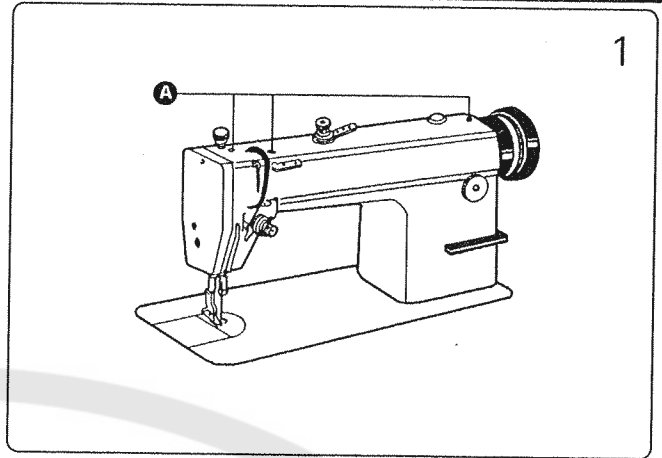

1. OIL FILLING (Fig. 2)

1). The oil amount in the oil reservoir is controlled through the reference marks A and B shown in Fig2. The mark A indicates the max. oil amount level, the mark B for the min. oil amount level. If the oil amount level is under the mark B, replenish the oil reservoir with oil in time.

2). When filling oil, loosen the oil draining screw (C), drain off the remaining oil in the oil reservoir completely, clean the oil reservoir and tighten the oil draining screw (C), then fill the oil reservoir with fresh oil.

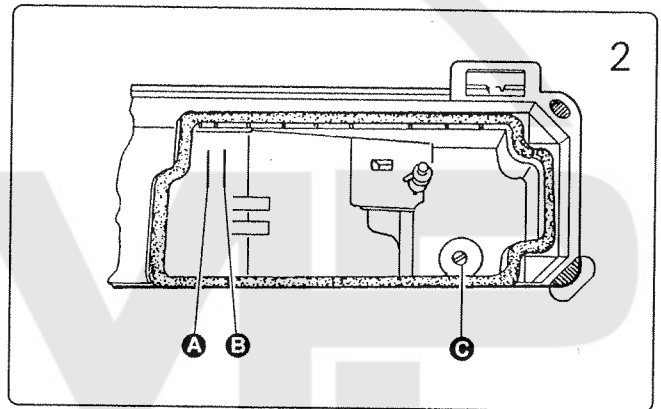

2. ROTATING HOOK OIL AMOUNT ADJUSTMENT (Fig. 3)

Adjust the oil amount of the rotating hook by turning the oil amount adjusting screw (A). Turn the screw (A) clockwise (in the "+" direction) to increase the oil amount; turn it counter-clockwise (in the "-" direction) to decrease the oil amount.

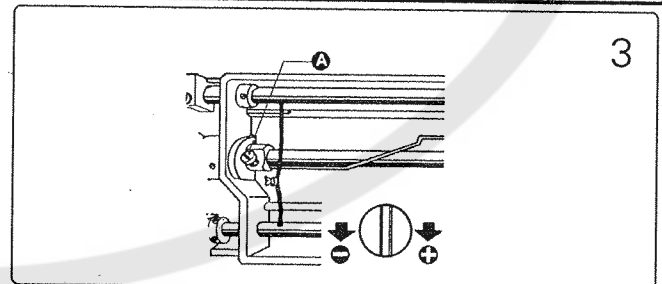

3. OIL PUMP ADJUSTMENT (Fig. 4)

In ordinary operation, adjustment is not required for the oil pump. If oil splashing does not occur in the oil check window when the machine runs at a low speed (approx. 2000 spm), close the clearance of the bypass oil hole.

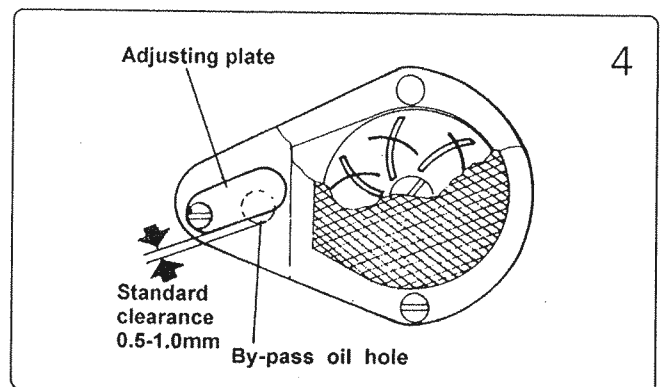

4. NEEDLE INSTALLATION (Fig. 5)

Turning the balance wheel to lift the needle bar to the upper end of its stroke. Loosen the needle clamp screw while keeping the long groove of the needle leftward, fully insert the needle shank up to the bottom of the needle socket, then tighten the needle clamp screw.

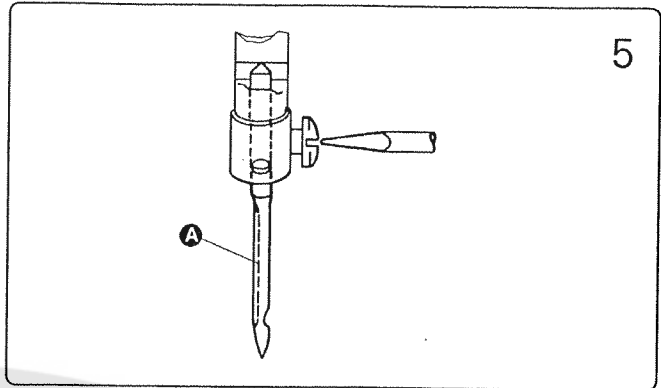

5. CONNECTION OF THE CLUTCH LEVER WITH THE PEDAL (Fig. 6)

- 1) . The optimum tilt angle of pedal is approximately 15 deg.
- 2) . Adjust the clutch so that the clutch lever (C) align with the draw bar (B) as shown in Fig. 6
- 3) . The machine pulley should rotate counter - clockwise when viewed from the outside of it. The rotating direction of the motor pulley can be reversed by turning the plug of the motor at 180 deg.
- 4) . Adjust the tension of O - belt (F) by moving the motor up and down. The proper tension of the O - belt is a slack of 10 - 20 mm when the belt is depressed at the center of the belt by finger.

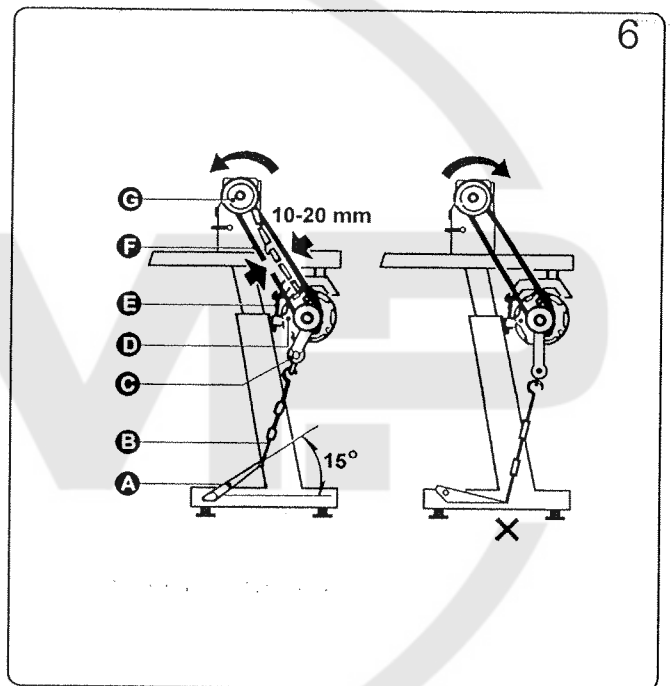

6. BELT COVER INSTALLATION (Fig. 7)

Install the belt cover for the sake of safety.
Install belt cover (C) to arm with screw (A) and screw (B), and install belt cover (E) on board with screw (D).

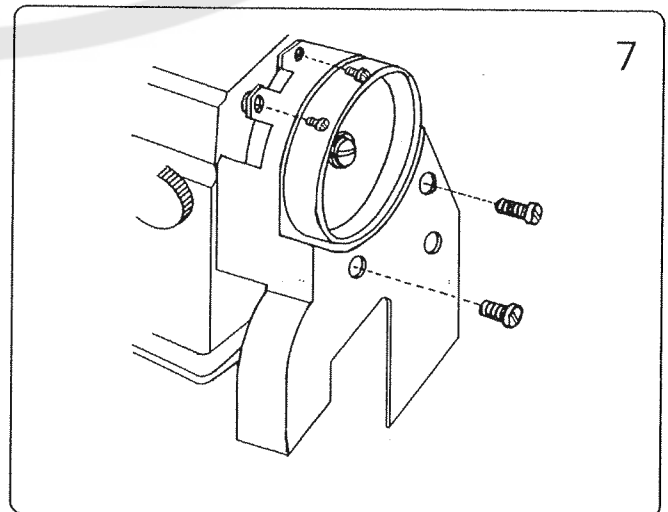

7. ADJUST THE OPENING TIME OF THE TENSION DISCS (Fig. 8)

Within the presser foot lift range , the opening time of the tension discs can be adjusted as follows:

1). Remove the rubber plug from the back of the arm and loosen the screw (A) of the knee lift lever (left).

2). Move the tension releasing cam (D) leftward for earlier opening or rightward for later opening . It will facilitate the adjustment if putting a block under the presser foot lift.

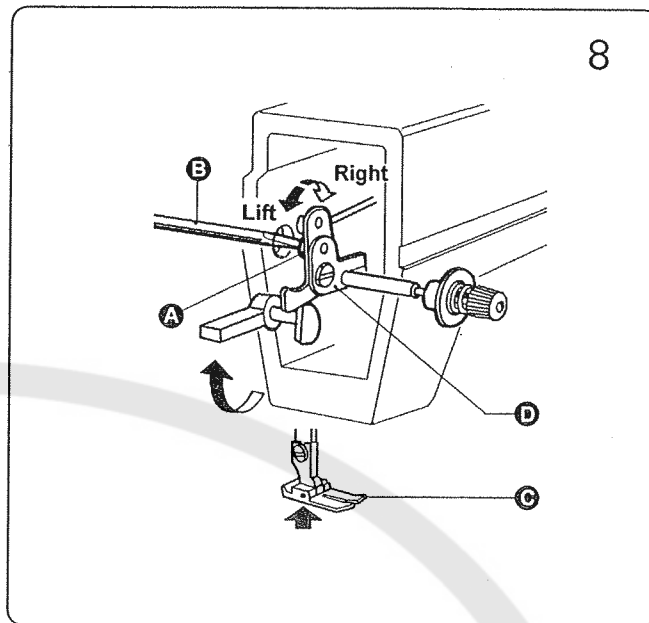

8. THREADING (Fig. 9)

To thread the needle thread, raise the needle bar to the upper end of its stroke , lead the thread from the spool and perform threading as shown in Fig.9. To draw the bobbin thread, hold the end of the needle thread and turn the balance wheel to lower the needle bar and then lift it to its highest position. Pull the ends of needle thread and bobbin thread frontward under presser foot.

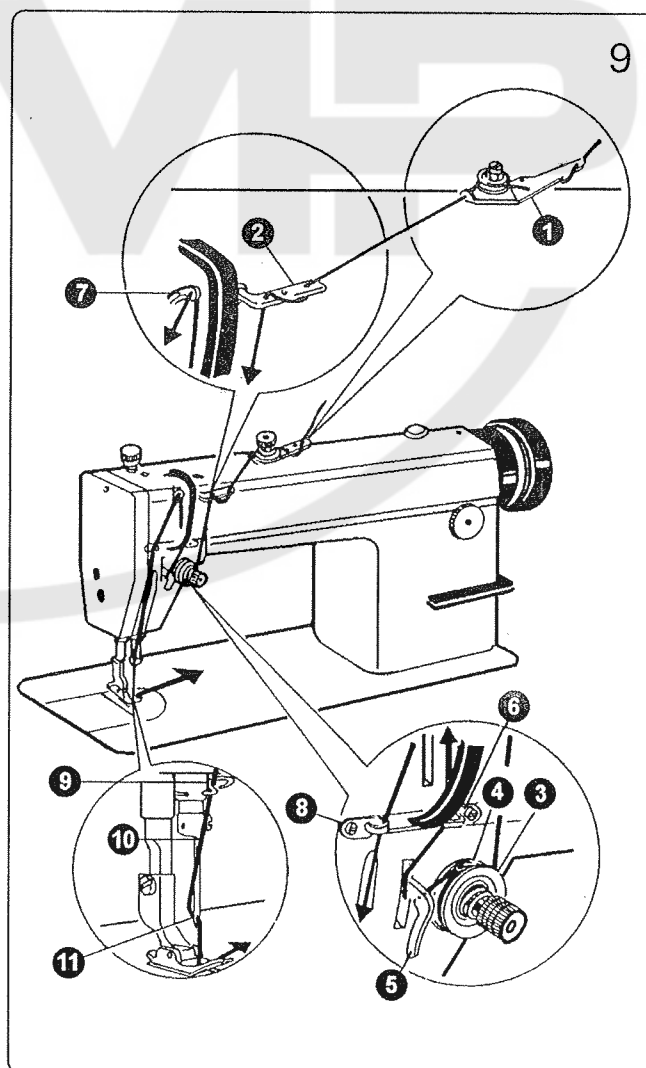

9. WINDING INSTALLATION AND ADJUSTMENT (Fig. 10)

The bobbin winder pulley should align with the V-belt and there should be some clearance between them. When the bobbin winder stop latch lever is depressed, the V-belt should be in touch with the bobbin winder pulley in order that the bobbin winder puller can be driven by the V-belt.

The thread wound on the bobbin should be neat and tight, if not tight, adjust the winding tension by turning the tension stud nut (A) of the bobbin winder tension bracket. When the thread wound on the bobbin does not present a cylindrical shape as shown in Fig. 10(a), loosen the set screw (B) of the bobbin winder tension bracket and move the bracket (C) leftward or rightward. If the thread is wound as shown in the figure (b), move the bracket rightward or if wound as shown in the figure (c), move it leftward. After positioning the bracket adequately, tighten the set screw (B).

Do not overfill the bobbin. The optimum wound length of the thread will fill about 80% of the bobbin capacity. This can be adjusted by the screw (E) of the bobbin winder stop latch.

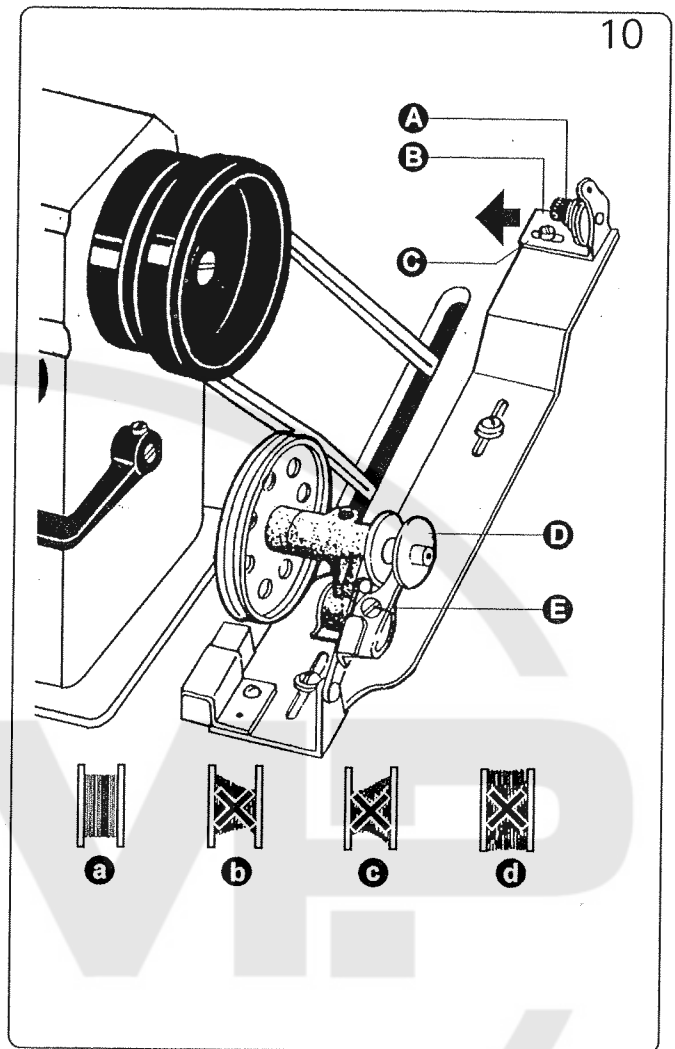

10. ADJUST THE PRESSURE OF PRESSER FOOT (Fig. 11)

Pressure of the presser foot is adjusted in accordance with thickness of materials to be sewn.

First loosen the lock nut (A), for heavy materials, turn the pressure regulating thumb screw as shown in Fig. 11(a) to increase the pressure, while for light materials, turn the pressure regulating thumb screw as shown in Fig. 11(b) to decrease the pressure, then tighten the lock nut (A).

The pressure of the presser foot is recommended to be less as long as normal feeding is ensured.

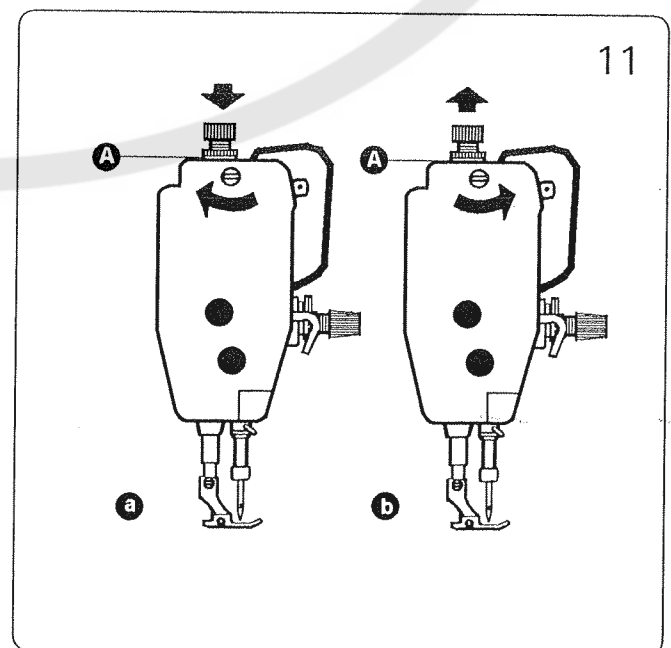

11. THREAD TENSION ADJUSTMENT (Fig. 12, 13, 14)

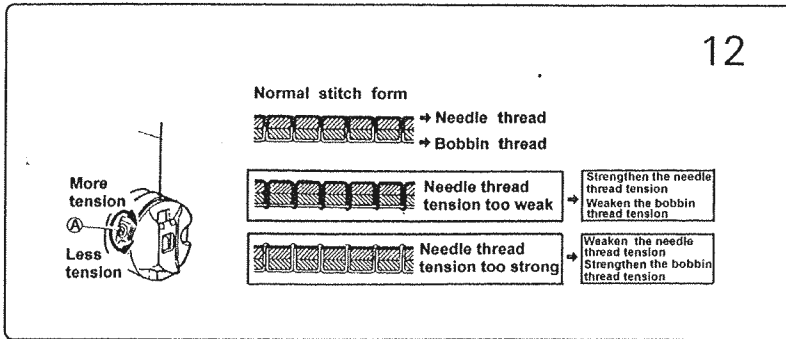

Thread tension should be determined in accordance with the stitches obtained by adjusting the tension of the bobbin thread and needle tension (Fig. 12).

The tension of the bobbin thread: to be adjusted by turning the tension spring regulating screw of the bobbin case. After adjusting, insert the bobbin into the bobbin case and hold the end of the thread from the bobbin case to hang the bobbin case, if the bobbin case falls slowly and evenly, the proper tension of the bobbin thread is obtained.

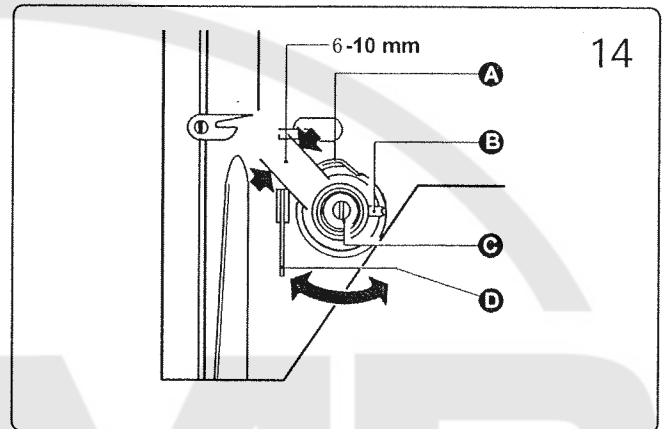
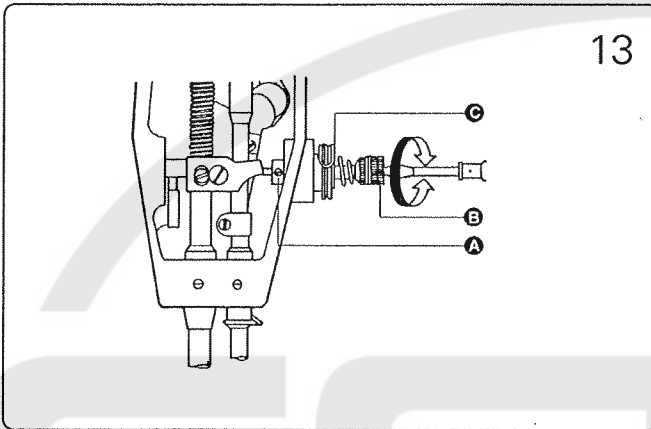

The tension of the needle thread: to be adjusted by turning the thumb nut.

The stroke of the thread take-up spring runs from 6mm to 10mm. When sewing very thin fabrics, reduce the thread take-up spring tension and increase the thread take-up spring stroke, whereas increase the thread take-up spring tension and reduce the thread take-up stroke when sewing very thick fabrics.

Adjusting the thread take-up spring tension: (Fig. 13) First loosen the set screw (A), turn the tension stud (B) counter-clockwise to decrease the tension of the thread take-up spring (C) to zero, then turn the tension stud (B) clockwise till the spring (C) comes to the notch of the tension regulating bushing, and again turn the tension stud (B) half way back (counter-clockwise). After the adjustment, tighten the set screw (A).

Adjusting the thread take-up spring stroke: (Fig. 14) Loosen the set screw (B), turn the stud (C) clockwise to increase the stroke or turn the stud (C) counter-clockwise to decrease the stroke. After the adjustment, tighten the set screw (B).

12. ADJUST THE SYNCHRONIZATION OF THE NEEDLE WITH ROTATING HOOK (Fig. 15, 16)

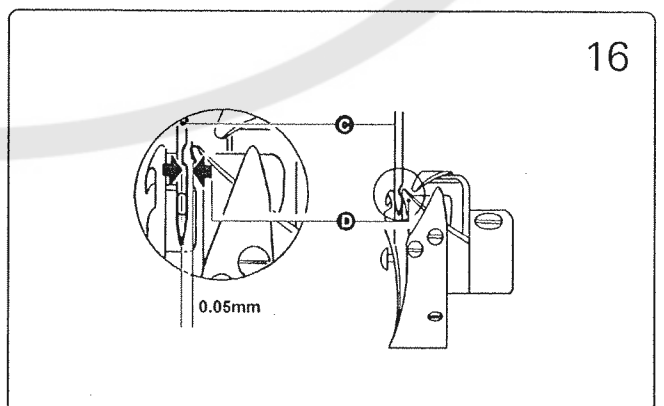
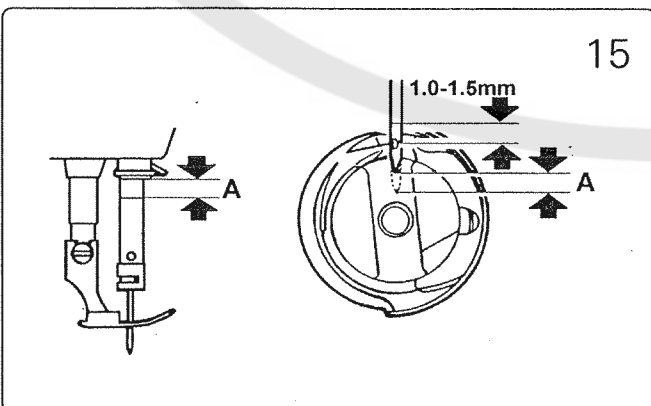

When lifting the needle bar from its lowest position of the stroke to the distance A, the hook point D of the bobbin should align with the center line of the needle and be 1.0 – 1.5 mm above the upper end of the needle eye. (Fig. 15)

The clearance between the bottom of the needle notch and the hook point should be 0.05 mm (Fig. 16).

Model	6160	6160H	6160B
A	2.2 mm	2.2mm	2.4mm

13. ADJUSTMENT OF STITCH LENGTH AND REVERSE FEEDING (Fig. 17)

The stitch length can be adjusted by turning the dial (A). The figures on the face (B) of the dial show the stitch length in mm.

The reverse feeding starts when the reverse feed lever (C) is depressed, the machine will feed forward again if the reverse feed lever is released.

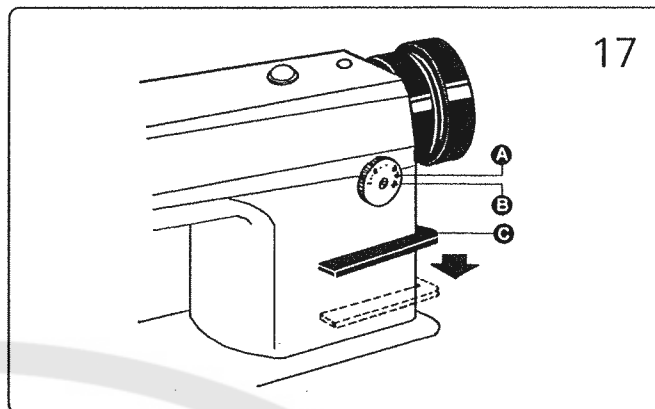

14. ADJUST THE SYNECHRONILATION OF THE NEEDLE MOTION WITH FEED MOTION (Fig. 18, 19)

To adjust the feed dog position (C), first should release the two set screw (F) and turn around the balance wheel by hand. When the needle (A) point reaches the surface of the throat plate (B), the top of the feed dog (C) should be flush with the throat plate surface.

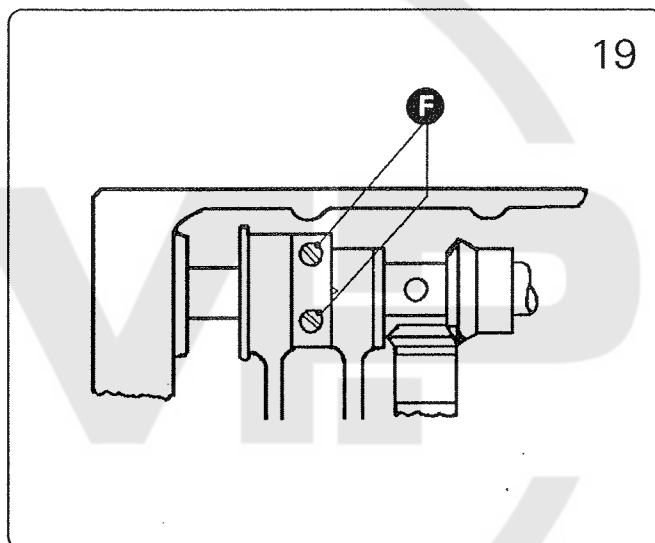
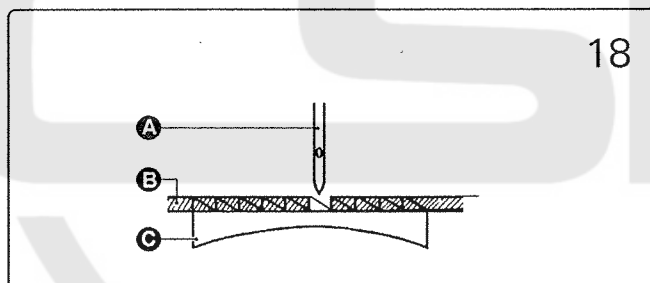

15. STITCH LENGTH ERROR ADJUSTMENT (Fig. 20)

Loosen screw (A) to adjust the stitch length adjusting cam (B). Turn it rightward to narrow the stitch length as forward sewing, and widen it as reverse sewing; turn it leftward to widen the stitch length as forward sewing, and narrow it as reverse sewing.

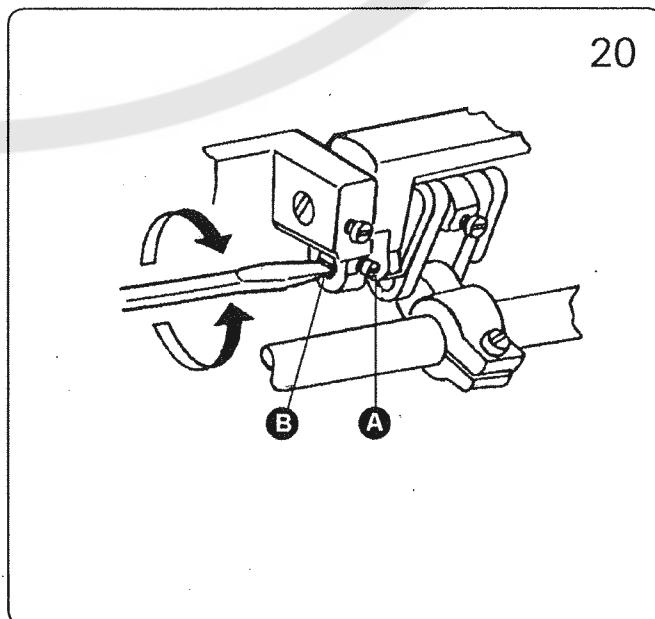

16. FEED DOG HORIZONTALITY ADJUSTMENT (Fig. 21)

Heighten the front of feed dog to prevent fabric from wrinkling, lower the front of feed dog to prevent fabric from defection, breaking of hook thread.

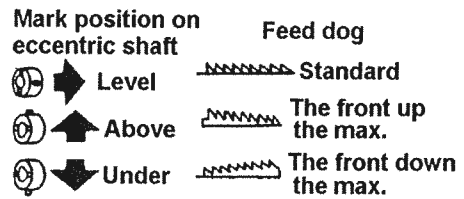

17. REGULAR CLEANING (Fig. 22. 23. 24)

1) Cleaning feed dog

Remove the throat plate and clear off the dust and lint between feed dog tooth slots.

2) Cleaning rotating hook

Swing out the machine head and clean the hook. Wipe the bobbin case with soft cloth.

3) Cleaning oil pump screen

Swing out the machine head and clear off the dust and dirt on oil pump screen.

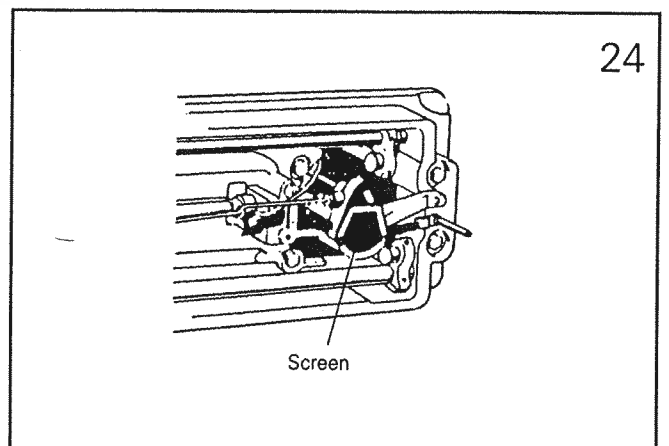
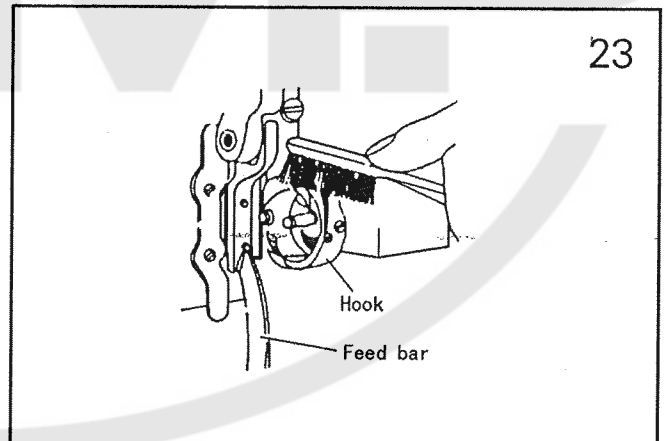
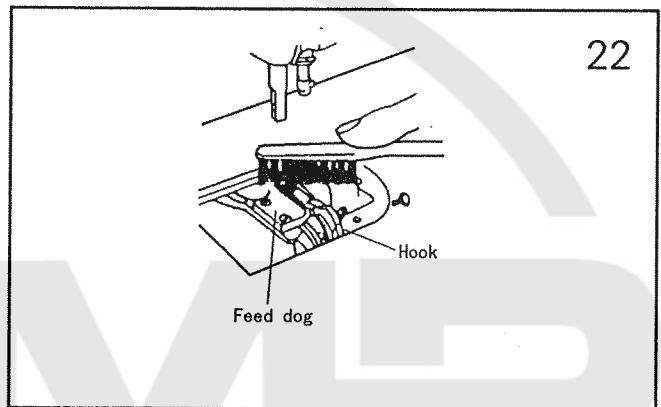

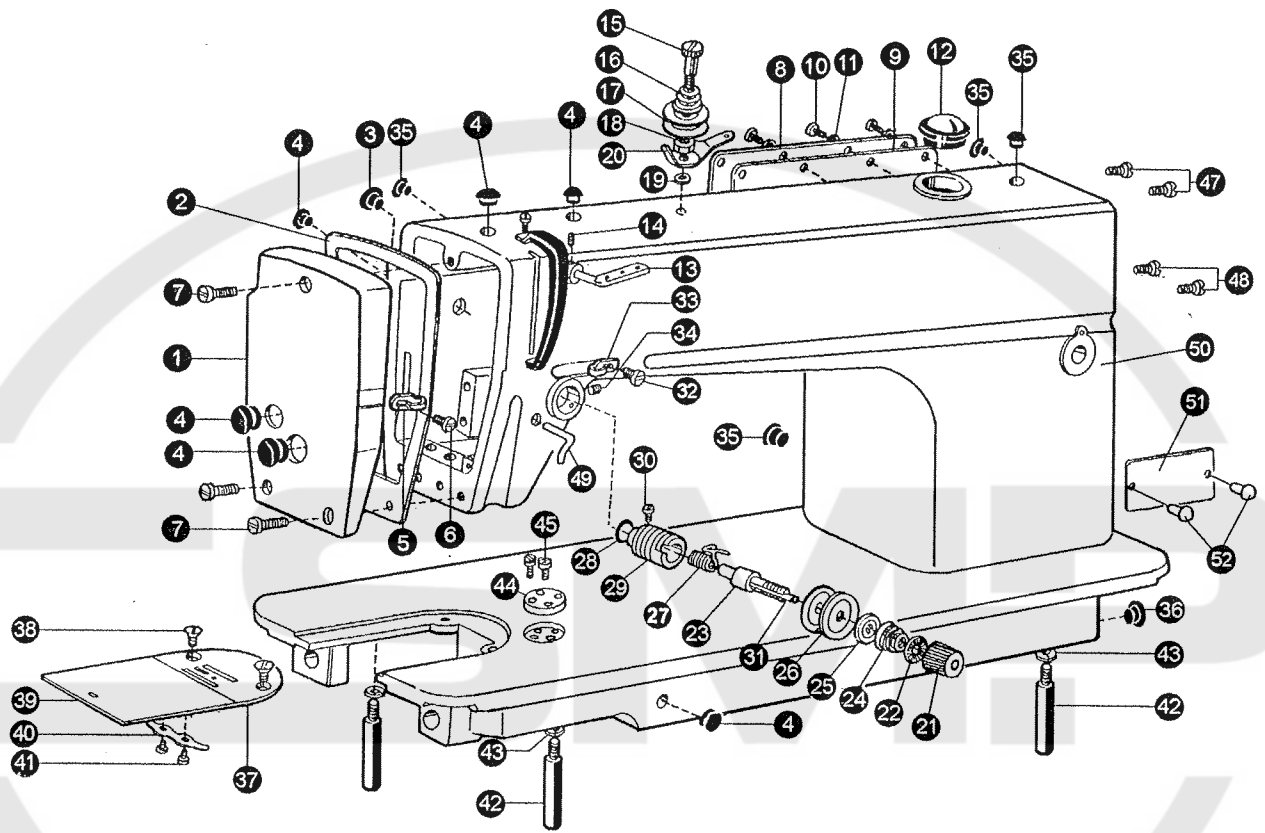

1. ARM BED AND ITS ACCESSORIES

No.	Ref. No.	Description	Qt.		
			M	H	B
1	027100002	Face plate	1	1	1
2	027100003	Gasket for face plate	1	1	1
3	22T1 -003C3	Rubber plug(Ø19)	1	1	1
4	22T1 -003C4	Rubber plug(Ø11.8)	6	6	6
5	22T1 -003C5	Threade guide on face plate	1	1	
	078130001	Threade guide on face plate			1
6	22T1 -003C6	Threade guide screw	1	1	1
7	22T1 -004	Face plate screw	3	3	3
8	22T1 -005D1	Back plate	1	1	1
9	22T1 -005D2	Gasket for rack plate	1	1	1
10	22T1 -006	Set screw	8	8	8
11	22T1 -007	Washer	8	8	8
12	22T1 -008H	Oil check window	1	1	1
13	22T1 -010	Three hole thread guide	1	1	1
14	28T4 -083	Set screw	1	1	1
15	22T1 -009E1	Screw	1	1	1
16	22T1 -009E2	Spring for pre - tension	1	1	1
17	22T1 -009E3	Discs for pre - tension	2	2	2
18	22T1 -009E4	Washer	1	1	1
19	GB896 -86	Spring washer 3	1	1	1
20	22T1 -009E5	Threade guide for pre - tension	1	1	1
21	124T1 -003C1	Knub for thread tension regulator	1	1	1
22	22T1 -012F10	Thumb nut revdution stoper	1	1	1
23	22T1 -012F11	Threade tension stud	1	1	1
24	22T1 -012F3	Threade tension spring	1		
	048110001	Threade tension spring		1	1
25	22T1 -012F4	Threade tension releasing disc	1	1	1
26	22T1 -012F5	Threade tension disc	2	2	2
27	22T1 -012F6	Threade take - up spring	1		
	048110002	Threade take - up spring		1	1
28	22T1 -012F11	Rubber ring	1	1	1
29	22T1 -012F7	Threade tension regulating bushing	1	1	1
30	22T1 -012F8	Set screw	1	1	1
31	22T1 -012F9	Threade tension releasing pin	1	1	1
32	22T1 -003C6	Set screw	1	1	1
33	22T1 -014	Threade guider for arm center	1	1	
	078100005	Threade guider for arm center			1
34	22T1 -013	Set screw	1	1	1
35	22T1 -015	Rubber plug(Ø8.8)	5	5	5
36	22T1 -016	Rubber plug(Ø27)	1	1	1
37	027100004	Needle plate	1		
	027100004	Needle plate		1	1
38	22T1 -020	Needle plate screw	2	2	2
39	22T1 -021G1	Slide plate	1	1	1
40	22T1 -021G2	Spring for slide plate	1	1	1
41	22T1 -021G3	Screw	2	2	2
42	48T1 -005	Leg	3	3	3
43	GB93 -87	Washer 6	3	3	3
44	57T1 -008	Ruler plate	1	1	1
45	124T1 -004	Ruler screw	2	2	2
47	22T1 -006	Screw	2	2	2
48	22T8 -009	Screw	2	2	2
49	027100005	Slack thread regulator	1	1	1
50	027101000	Machine arm assembly	1	1	
	027101100	Machine arm assembly			1
51	027100001	Trade mark plate	1		
	027100101	Trade mark plate		1	
	027100201	Trade mark plate			1
52	GB827 -86	Rivet(2.5 x5)	2	2	2

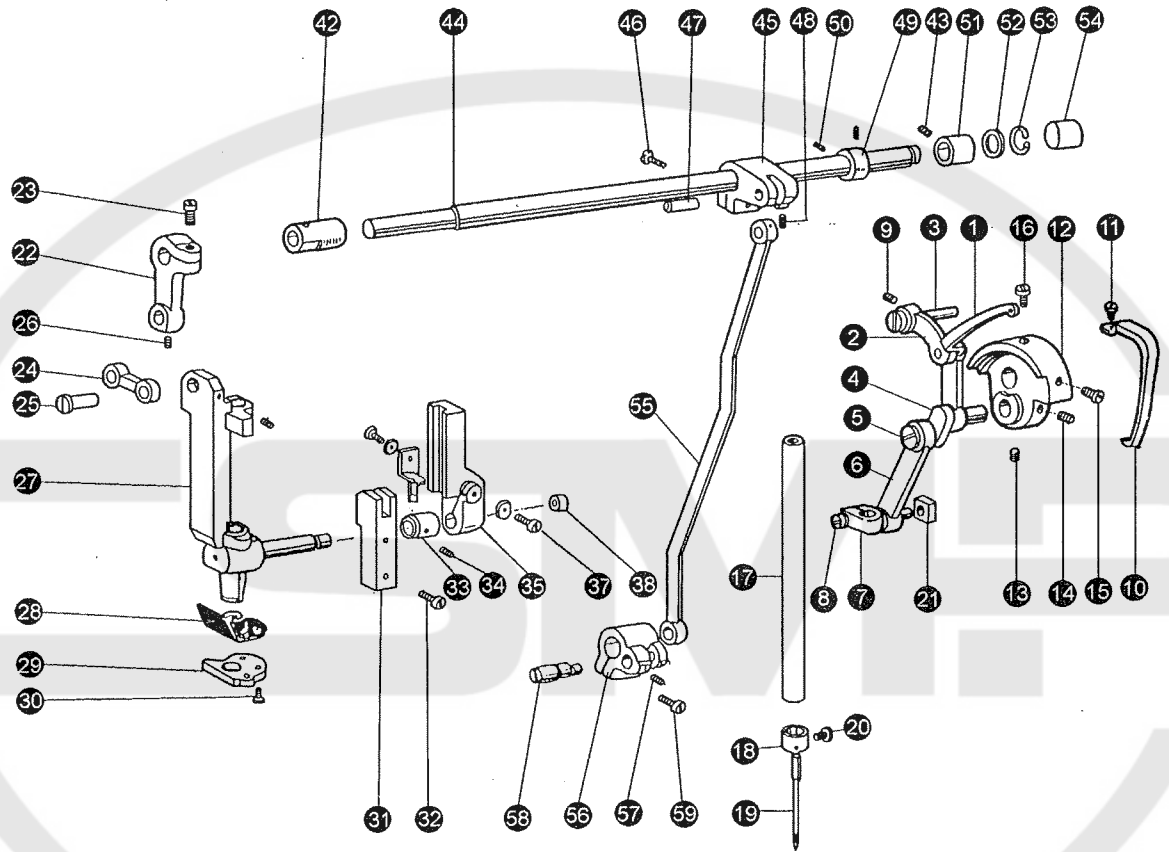

2. NEEDLE MECHANISM

No.	Ref. No.	Description	Qt.		
			M	H	B
1	22T2 -001A1a	Thread take -up lever	1		
	48T2 -001A1a	Thread take -up lever		1	
	78T2 -001A1a	Thread take -up lever			1
2	22T2 -001A2	Thread take -up link	1	1	1
3	22T2 -001A3	Thread take -up lever hinge pin	1	1	1
4	22T2 -001A4	Thread take -up crank	1		
	78T2 -001A2	Thread take -up crank		1	1
	22T2 -001A5	Needle roller bearing	2	2	2
5	22T2 -001A6	Set screw (left hand thread)	1	1	1
6	22T2 -001A7b	Needle bar link ass	1		
	48T2 -001A2	Needle bar link		1	1
7	22T2 -001A8	Needle bar connecting bar joint	1	1	1
8	22T2 -001A9	Screw	1	1	1
9	22T1 -006	Screw	1	1	1
10	36T2 -007	Take -up lever guard	1	1	
	078200002	Take -up lever guard			1
11	22T2 -004	Screw	1	1	1
12	22T2 -005B1	Needle bar crank	1		
	048220001	Needle bar crank		1	1
13	22T2 -005B2	Screw	1	1	1
14	22T2 -005B3	Thread take -up crank position screw	1	1	1
15	22T2 -006	Screw	1	1	1
16	22T2 -007	Thread take -up crank position screw	1	1	1
17	153200001	Needle bar	1	1	1
18	22T2 -015	Thread guide for needle bar	1	1	1
19	58T3 -001A10	Needle (DP x5 14#)	1		
	S150901003	Needle (DP x5 22#)		1	1
20	22T2 -017	Needle clamp screw	1	1	1
21	22T2 -020	Slide block	1		
	027200104	Slide block		1	1
22	027200001	Needle bar vibrating lever	1	1	1
23	22T6 -016	Screw	1	1	1
24	027200002	Needle bar vibrating connecting lever	1	1	1
25	027200003	Pin	2	2	2
26	22T1 -011	Screw	1	1	1
27	027201000	Needle bar holder assembly	1		
	027201100	Needle bar holder assembly		1	1
28	027200004	Oil guard felt	1	1	1
29	027200005	Set plate	1	1	1

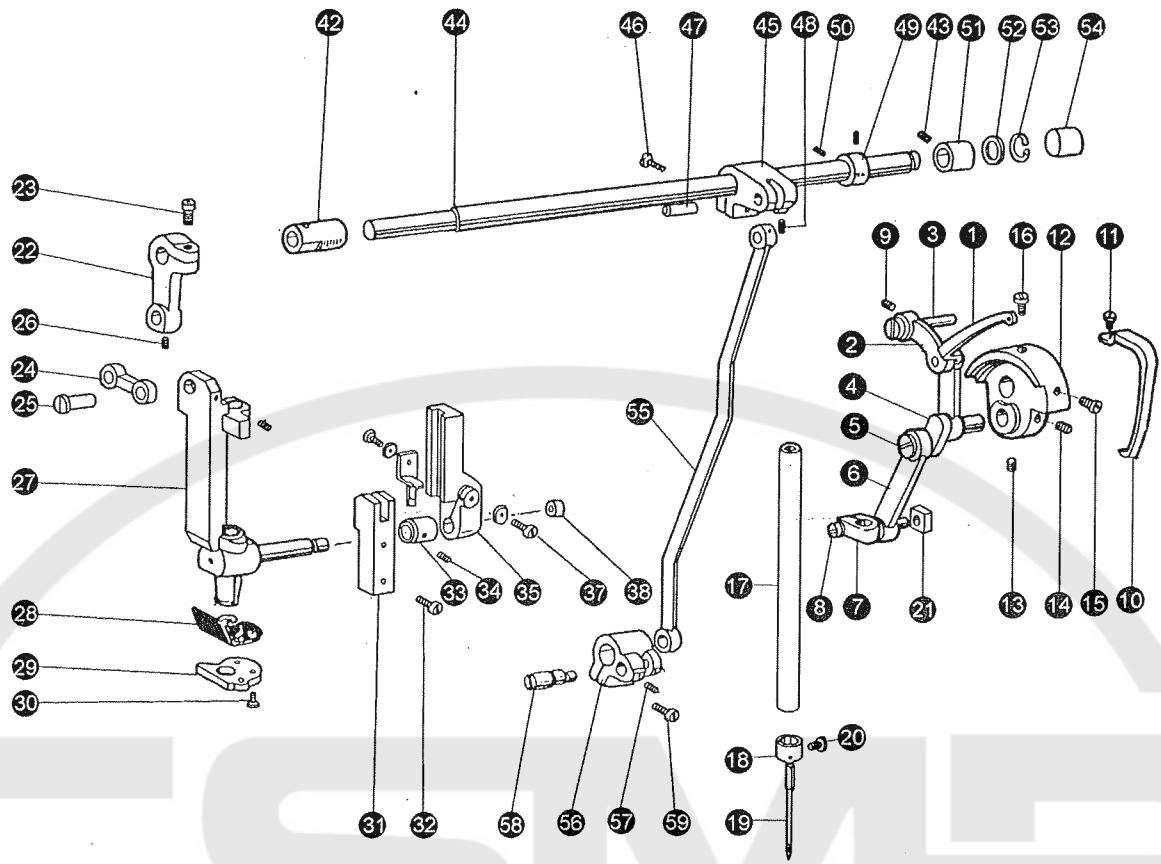

2. NEEDLE MECH ANISM

No.	Ref. No.	Description	Qt.		
			M	H	B
30	165330001	Screw	3	3	3
31	027200006	Needle bar holder guide	1	1	1
32	22T2 -019	Screw	1	1	1
33	027200007	Bushing	1	1	1
34	22T1 -011	Screw	1	1	1
35	027200008	Needle bar sliding block guide	1	1	1
37	22T6 -016	Screw	1	1	1
38	027200009	Needle roller bearing	1	1	1
42	027200011	Vibrating shaft bushing (left)	1	1	1
43	22T1 -011	Screw	1	1	1
44	027200012	Vibrating shaft	1	1	1
45	027200013	Vibrating shaft crank	1	1	1
46	22T6 -001A1b	Screw	1	1	1
47	027200014	Pin	1	1	1
48	22T1 -011	Screw	1	1	1
49	027200015	Collar	1	1	1
50	22T3 -002B2	Screw	2	2	2
51	027200016	Vibrating shaft bushing (right)	1	1	1
52	027200017	Washer	1	1	1
53	GB8894. 2 -86 - 12	Vibrating shaft stop ring 12	1	1	1
54	027200018	Rubber plug (Ø21. 5)	1	1	1
55	027200019	Feed link (long)	1	1	1
56	027200020	Feed crank	1	1	1
57	22T6 -016	Screw	1	1	1
58	027200021	Eccentric shaft	1	1	1
59	22T1 -011	Screw	1	1	1

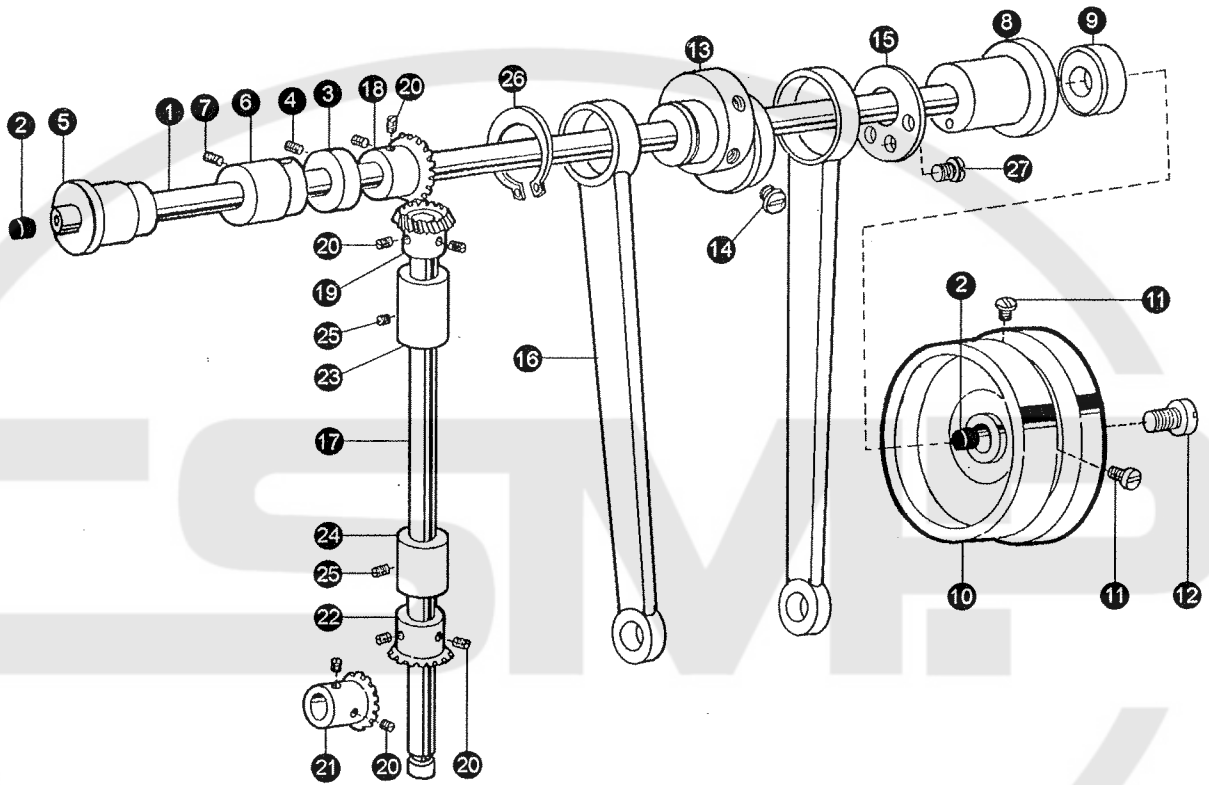

3. ARM SHAFT AND VERTICAL SHAFT MECHANISM

No.	Ref. No.	Description	Qt.		
			M	H	B
1	1533100001	Arm shaft	1	1	1
2	22T3 -001A2	Arm shaft rubber plug($\varnothing 7.4 \times 10$)	2	2	2
3	22T3 -002B1	Collar for arm shaft	1	1	1
4	22T2 -005B3	Set screw	2	2	2
5	22T2 -003	Arm shaft bushing(left)	1	1	1
6	22T3 -004	Arm shaft bushing(middle)	1	1	1
7	22T2 -002	Set screw	1	1	1
8	124T3 -003C1	Arm shaft bushing(right)	1	1	1
9	124T3 -003C2	Oil seal	1	1	1
10	153300001	Balance wheel	1	1	1
11	22T3 -007C2	Set screw	2	2	2
12	22T3 -008	Set screw	1	1	1
13	027300001	Eccentric wheel	1	1	1
14	58T5 -012F2	Eccentric wheel screw	2	2	2
15	36T3 -004	Spacer	1	1	1
16	22T3 -009D1c	Crank rod for lifting rock shaft	1	1	1
17	22T3 -010E1	Vertical shaft	1	1	1
18	22T3 -010E2a1 -2	Bever gear for arm shaft(Z =27)	1	1	1
19	22T3 -010E2a2 -2	Bever gear for vertical shaft(upper) (Z =18)	1	1	1
20	22T2 -005B3	Set screw	8	8	8
21	22T3 -010E2b1 -2	Bever gear for hook shaft(Z =21)	1	1	1
22	22T3 -010E2b2 -2	Bever gear for Vertical shaft(lower) (Z =28)	1	1	1
23	22T3 -011	Vertical shaft bushing(upper)	1	1	1
24	22T3 -012	Vertical shaft bushing(lower)	1	1	1
25	22T2 -002	Set screw	2	2	2
26	22T3 -009D1b	Ring	1	1	1
27	165330001	Screw	3	3	3

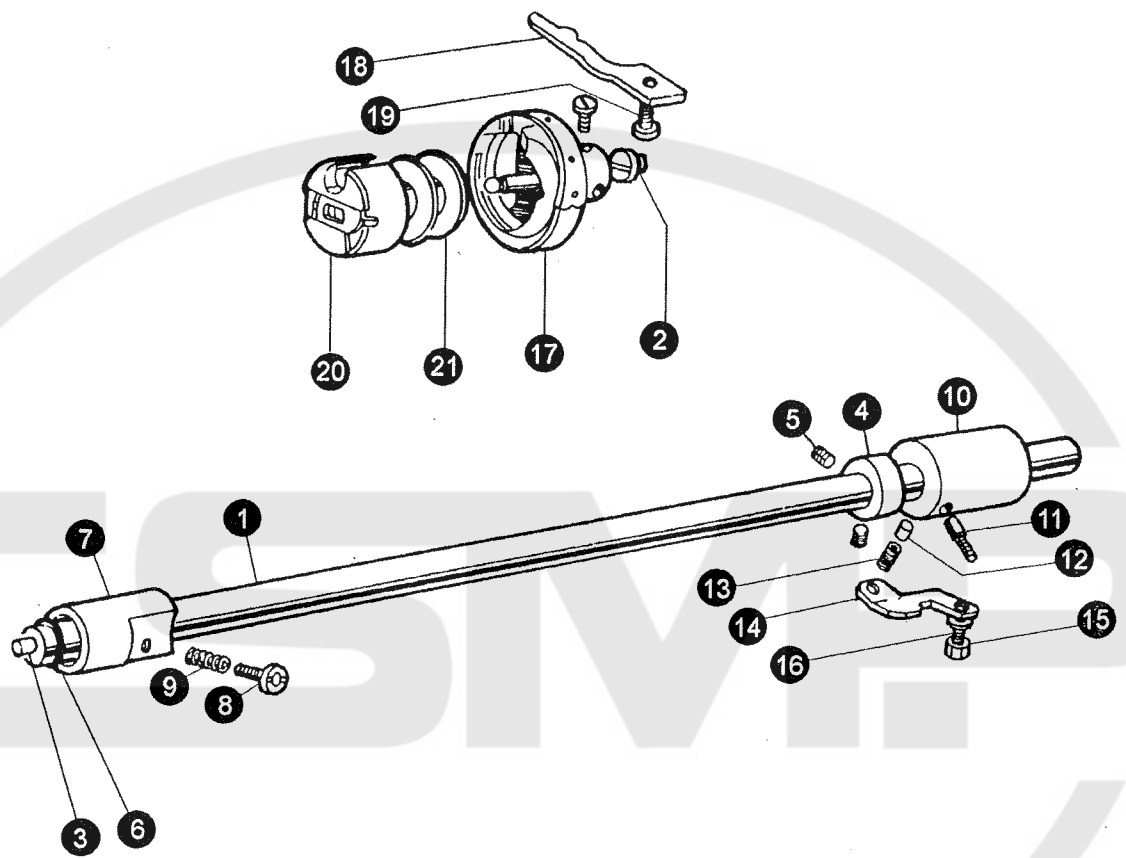

4. ROTATING HOOK MECHANISM

No.	Ref. No.	Description	Qt.		
			M	H	B
1	36T4 - 008D1	Hook shaft	1	1	
	120400001	Hook shaft			1
2	22T4 - 001A1a1	Filter screw	1	1	1
3	22T4 - 001A1a2	Filter	1	1	1
4	22T4 - 002B1	Collaer for hook shaft	1	1	1
5	22T2 - 009	Set screw	2	2	2
6	22T4 - 003G	Oil seal for rotating	1	1	1
7	22T4 - 004	Hook shaft bushing (left)	1	1	1
8	22T4 - 005	Oil adjusting screw	1	1	1
9	22T4 - 006	Spring for oil adjusting	1	1	1
10	36T4 - 014F1	Hook shaft bushing (right)	1	1	1
11	22T4 - 007C2	Oil pipe for hook shaft bushing	1	1	1
12	36T4 - 015	Plunger	1	1	1
13	36T4 - 016	Plunger spring	1	1	1
14	22T4 - 001A1	Guide plate	1	1	
	78400006	Guide plate			1
15	22T8 - 009	Screw	1	1	1
16	GB93 - 87 - 6	Spring washer 6	1	1	1
17	KSH12 - SD	Rotating hook	1		
	048400101	Rotating hook		1	
	027403000	Rotating hook			1
18	22T4 - 013	Rotating hook positioner	1		
	048400002	Rotating hook positioner		1	
	78T4 - 003	Rotating hook positioner			1
19	22T4 - 015	Screw	1	1	1
20	SC82 - J	Bobbin case	1	1	
	027402100	Bobbin case			1
21	36T4 - 006	Bobbin	1	1	
	078400005	Bobbin			1

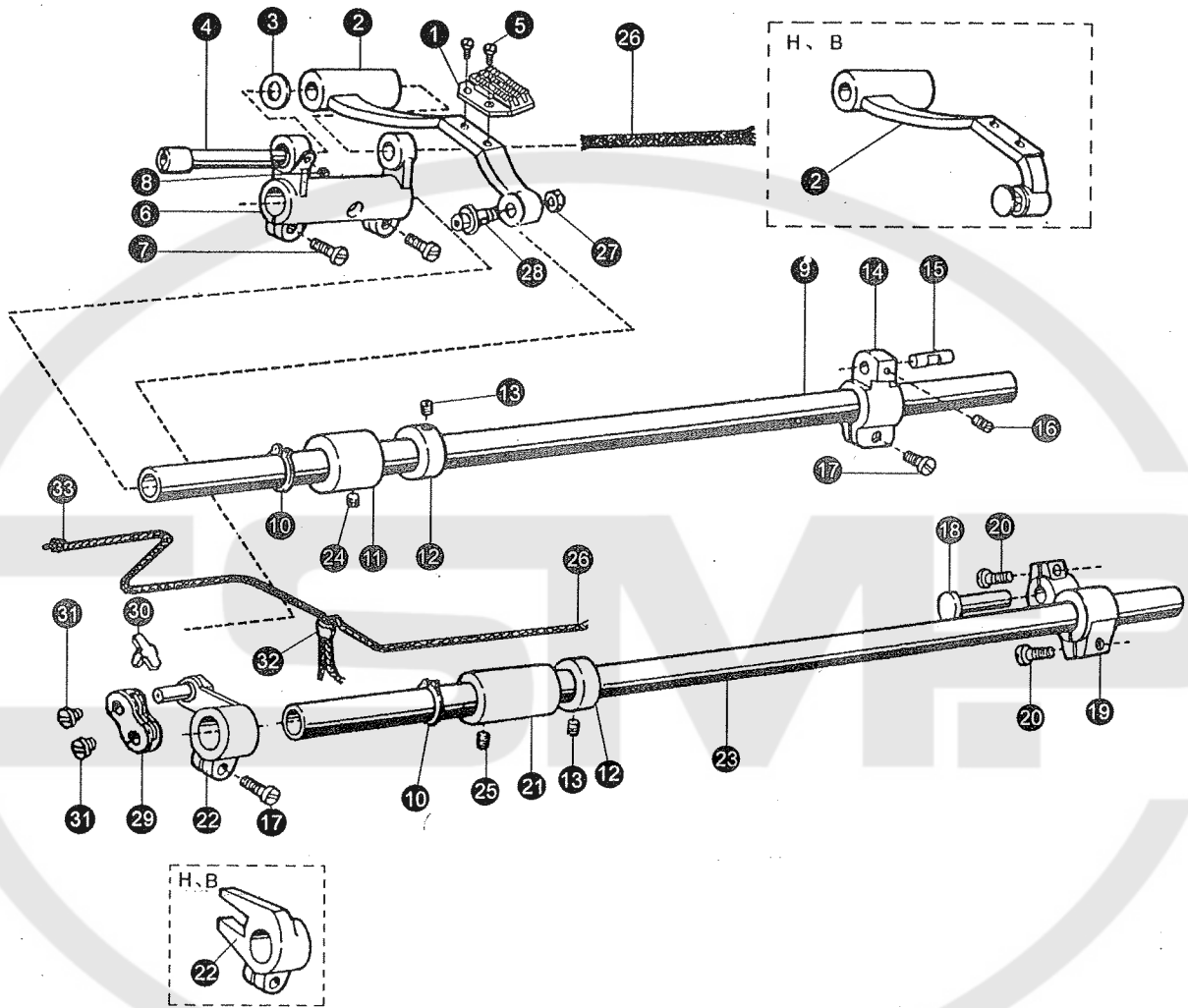

5. FEEDING AND FEED LIFTING MECHANISM

No.	Ref. No.	Description	Qt.		
			M	H	B
1	027600001	Feed dog	1		
	027600101	Feed dog		1	1
2	027601000	Feed bar	1		
	36T4 -001A1a	Feed bar		1	1
3	22T6 -001A6	Washer	1	1	1
4	36T4 -001A2	Feed bracket shaft	1	1	1
5	22T6 -001A4	Screw	2	2	2
6	22T6 -001A1a	Feed rock bracket arm	1	1	1
7	22T6 -001A1b	Screw	2	2	2
8	22T2 -019	Screw	1	1	1
9	124T6 -002	Feed rock shaft	1	1	1
10	GB894. 1 -86	C -type stop ring (15)	2	2	2
11	22T6 -004	Feed rock shaft bushing	1	1	1
12	22T6 -005B1	Collar	2	2	2
13	22T6 -005B2	Set screw	4	4	4
14	36T4 -003	Feed rock shaft crank(right)	1	1	1
15	36T4 -004H01	Feed link stod	1	1	1
16	36T5 -008E5	Set screw	1	1	1
17	22T6 -008D3	Screw	2	2	2
18	22T6 -007	Hinge	1	1	1
19	48T6 -006	Feed lifting rock shaft crank(right)	1	1	1
20	22T6 -016	Screw	2	2	2
21	22T6 -012	Bushing for feed lifting rock shaft	1	1	1
22	22T6 -008D	Feed lifting rock shaft crank assembly	1		
	36T4 -018H1D1	Feed lifting shaft crank		1	1
23	124T6 -003	Feed lifting rock shaft	1	1	1
24	22T2 -009	Set screw	1	1	1
25	22T2 -002	Set screw	1	1	1
26	22T6 -009F3	Wick	2	2	2
27	22T6 -001A8	Nut	1		
28	22T6 -001A9	Hinge	1		
29	22T6 -009F1	Feed stand link	1		
30	22T6 -009F2	Oil wick clamp	1		
31	22T6 -010	Screw	1		
32	22T6 -015	Oil wick clamp	1	1	1
33	22T6 -001A7	Oil wick	1	1	1

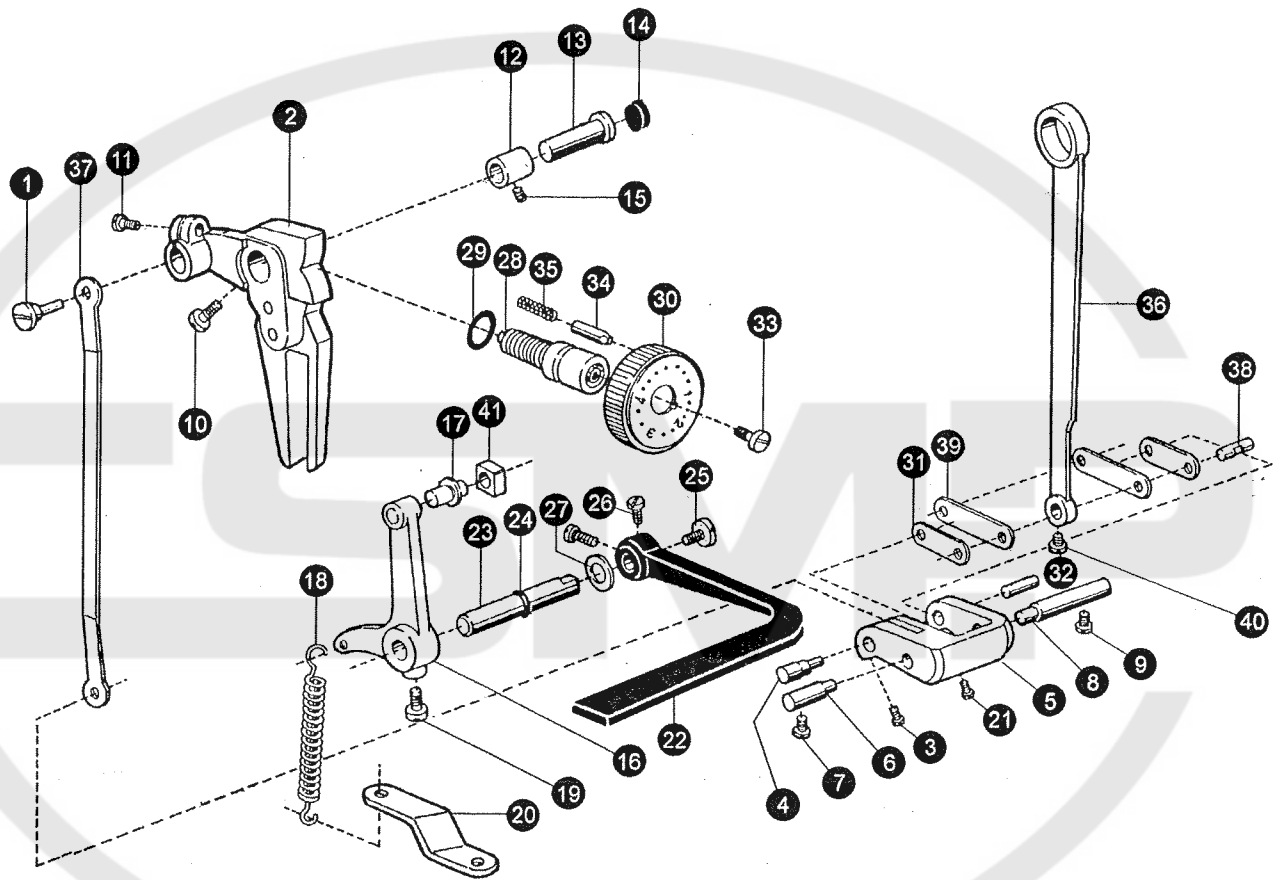

6. STITCH LENGTH REGULATING MECHANISM

No.	Ref. No.	Description	Qt.		
			M	H	B
1	36T5 - 001	Connecting stud	1	1	1
2	57T5 - 001	Feed regulator	1	1	1
3	36T5 - 008E8	Screw	1	1	1
4	36T5 - 008E9	Lever link eccentric shaft	1	1	1
5	36T5 - 008E10	Lever regulator	1	1	1
6	36T5 - 009H02	Pin(left)	1	1	1
7	22T6 - 008D3	Screw	1	1	1
8	36T5 - 009H01	Pin(right)	1	1	1
9	22T6 - 008D3	Screw	1	1	1
10	22T5 - 010D4	Screw of feed regulator	1	1	1
11	22T2 - 019	Screw	1	1	1
12	22T5 - 003	Feed regulator bushing	1	1	1
13	22T5 - 004	Feed regulator shaft	1	1	1
14	36T5 - 003	Rubber plug (Ø20)	1	1	1
15	22T2 - 002	Set screw	1	1	1
16	22T5 - 012E1	Back tacking crank	1	1	1
17	22T5 - 012E1a1	Slide block pin	1	1	1
18	57T5 - 004B1	Lever spring	1	1	1
19	22T5 - 013	Set screw	1	1	1
20	57T5 - 005	Bracket for spring	1	1	1
21	36T5 - 008E7	Screw	1	1	1
22	124500004	Backtacking lever	1	1	1
23	36T5 - 006C1a1	Backtacking lever shaft	1	1	1
24	GB3452. 1 - 92	O - ring (6. 3 x 1. 8G)	1	1	1
25	22T5 - 010D3	Screw	1	1	1
26	22T5 - 010D4	Screw	2	2	2
27	22T5 - 011	O - ring	1	1	1
28	124T5 - 001A2	Feed regulator screw	1	1	1
29	124T5 - 001A3	O - ring for feed regulating screw	1	1	1
30	027500001	Knob	1		
	124T5 - 002B1	Knob		1	
	124T5 - 001A1	Knob			1
31	36T5 - 008E4H01	Feed rock link	1	1	1
32	36T5 - 008E6	Pin	1	1	1
33	22T5 - 006C3	Screw	1	1	1
34	22T5 - 008	Stopper pin	1	1	1
35	22T5 - 009	Spring for stopper pin	1	1	1
36	36T5 - 008E2	Lever feed connecting rod	1	1	1
37	36T5 - 008E3	Feed regulator link	1	1	1
38	36T4 - 004H02	Sink shaft	1	1	1
39	36T5 - 008E4H02	Feed rock arm link	2	2	2
40	36T5 - 008E5	Screw	1	1	1
41	22T5 - 012E1a2	Crank slide block	1	1	1

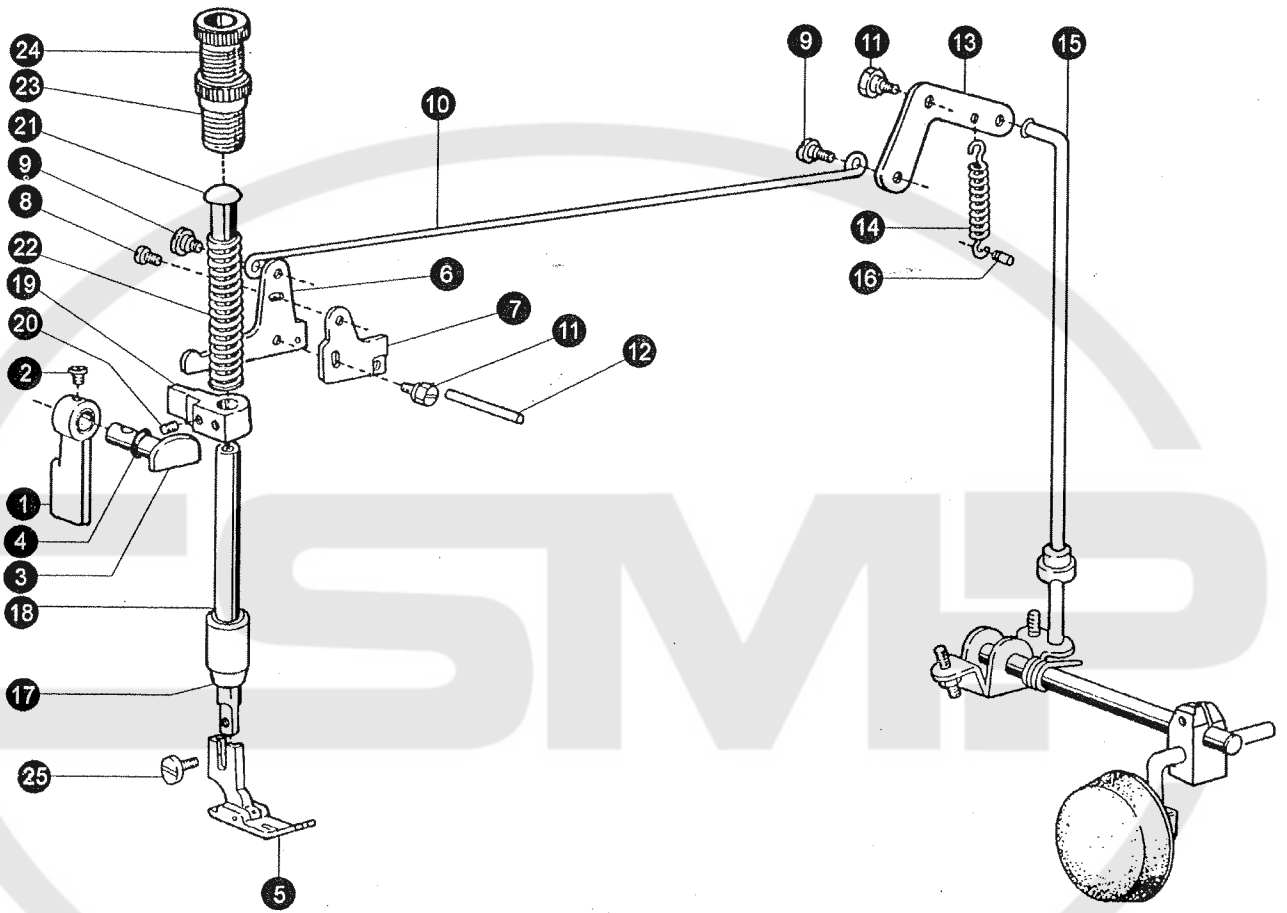

7. PRESSER FOOT MECHANISM

No.	Ref. No.	Description	Qt.		
			M	H	B
1	22T7 - 001A1	Presser bar lifter	1	1	1
2	22T1 - 006	Set screw	1	1	1
3	22T7 - 002	Presser bar lifter	1	1	1
4	GB3452. 1 - 92	Oil seal for presser bar(4.5 x 1.8G)	1	1	1
5	027701000	Presser foot complete	1		
	027701100	Presser foot complete		1	1
6	22T7 - 004B1a	Knee lifter lever(left)	1	1	1
7	22T7 - 004B1b	Tension releasing cam	1	1	1
8	22T7 - 004B1c	Screw	1	1	1
9	22T7 - 004B2	Hinge screw	2	2	2
10	22T7 - 004B3	Knee lifter rod	1	1	1
11	22T7 - 005	Bolt for tension releasing cam	1	1	1
12	22T7 - 006	Tension releasing pin	1	1	1
13	22T7 - 007C1	Knee lifte lever(right)	1	1	1
14	22T7 - 007C2	Spring for knee lifter lever(right)	1	1	1
15	22T7 - 007C3	Knee lifter connecting rod	1	1	1
16	22T7 - 008	Pin for spring	1	1	1
17	22T7 - 009	Presser bar bushing	1	1	1
18	22T7 - 010	Presser bar	1	1	1
19	027700001	Presser bar lifting bracket	1	1	1
20	22T1 - 013	Set screw	1	1	1
21	22T7 - 012	Presser bar guide	1	1	1
22	22T7 - 013	Presser spring	1		
	048700002	Presser spring		1	1
23	22T7 - 014E1	Presser regulating thumb screw	1	1	1
24	22T7 - 014E2	Presser regulating thumb nut	1	1	1
25	22T7 - 015	Set screw	1	1	1

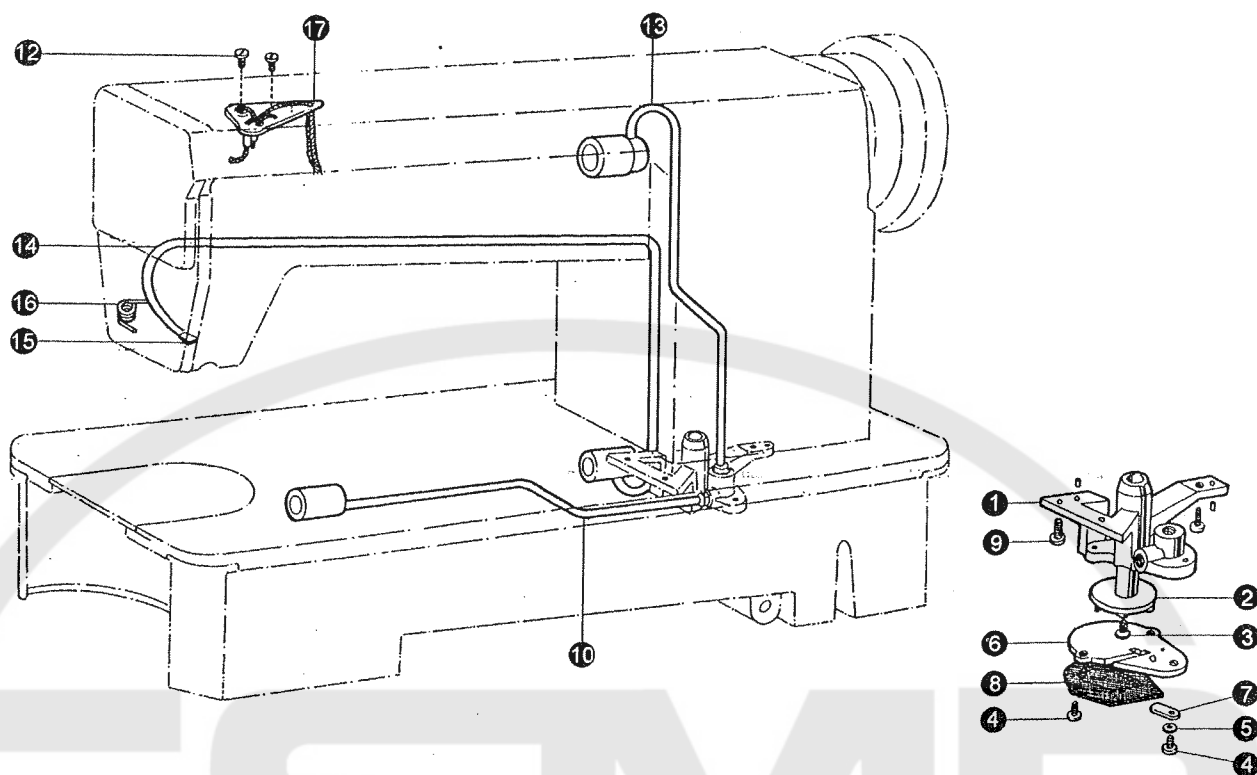

8. LUBRICATION MECHANISM

No.	Ref. No.	Description	Qt.		
			M	H	B
1	22T8 -001	Oil pump body	1	1	1
2	22T8 -002	Oil pump impeller	1	1	1
3	22T8 -003	Screw	1	1	1
4	22T8 -004	Screw	3	3	3
5	GB93 -87	Spring washer 3	1	1	
6	22T8 -006	Oil pump filtering plate	1	1	
	78T8 -001	Oil pump filtering plate			1
7	22T8 -007	Oil adjusting plate	1	1	
8	22T8 -008A	Oil pump screen complete	1	1	1
9	22T8 -009	Screw	3	3	3
10	22T8 -010B	Oil pipe for hook shaft	1	1	1
12	22T7 -012	Screw	2	2	2
13	22T8 -013D	Oil pipe for arm shaft	1	1	
	78T8 -002A	Oil pipe for arm shaft			1
14	027800001	Oil returning pipe	1	1	1
15	027800002	Felt pouch for return filter	1	1	1
16	027800003	Spring for oil felt	1	1	1
17	027810000	Oil braid filtering plate	1	1	1

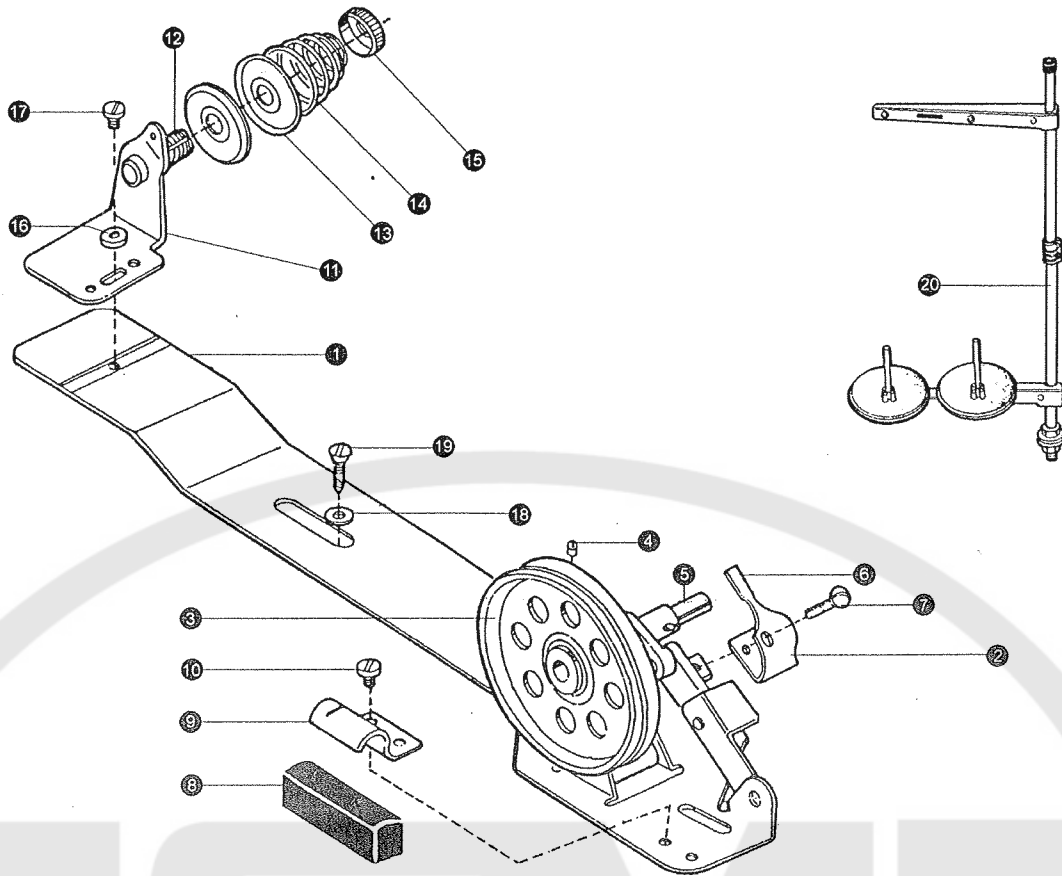

10. BOBBIN WINDER, SPOOL STAND MECHANISM

No.	Ref. No.	Description	Qt.		
			M	H	B
1	6F0 -001A	Bobbin winder base	1	1	1
2	6F0 -001A6a	Bobbin winder stop latchlever set	1	1	1
3	6F0 -002	Bobbin winder pulley	1	1	1
4	01/B112	Screw	1	1	1
5	6F0 -003	Bobbin winder spindle	1	1	1
6	6F0 -004 -1	Bobbin winder stop latch	1	1	
	6F0 -004 -2	Bobbin winder stop latch			1
7	6F0 -005	Adjusting screw	1	1	1
8	6F0 -006	Stopper block	1	1	1
9	6F0 -007	Stopper block clamp	1	1	1
10	6F0 -008	Set screw	1	1	1
11	6F0 -009B1b1	Bobbin winder tension bracket	1	1	1
12	17T7 -017	Bobbin winder tension stud	1	1	1
13	22T1 -012F5	Bobbin winder tension discs	2	2	2
14	22T1 -012F3	Bobbin winder tension spring	1	1	1
15	J2. 2. 7	Tension stud nut	1	1	1
16	BQ10021	Screw	1	1	1
17	22T2 -004	Tension bracket screw	1	1	1
18	GB848 -85	Washer 6	2	2	2
19	GB99 -86	Wood screw	2	2	2
20	GXJ -2	Spool stand	1	1	1

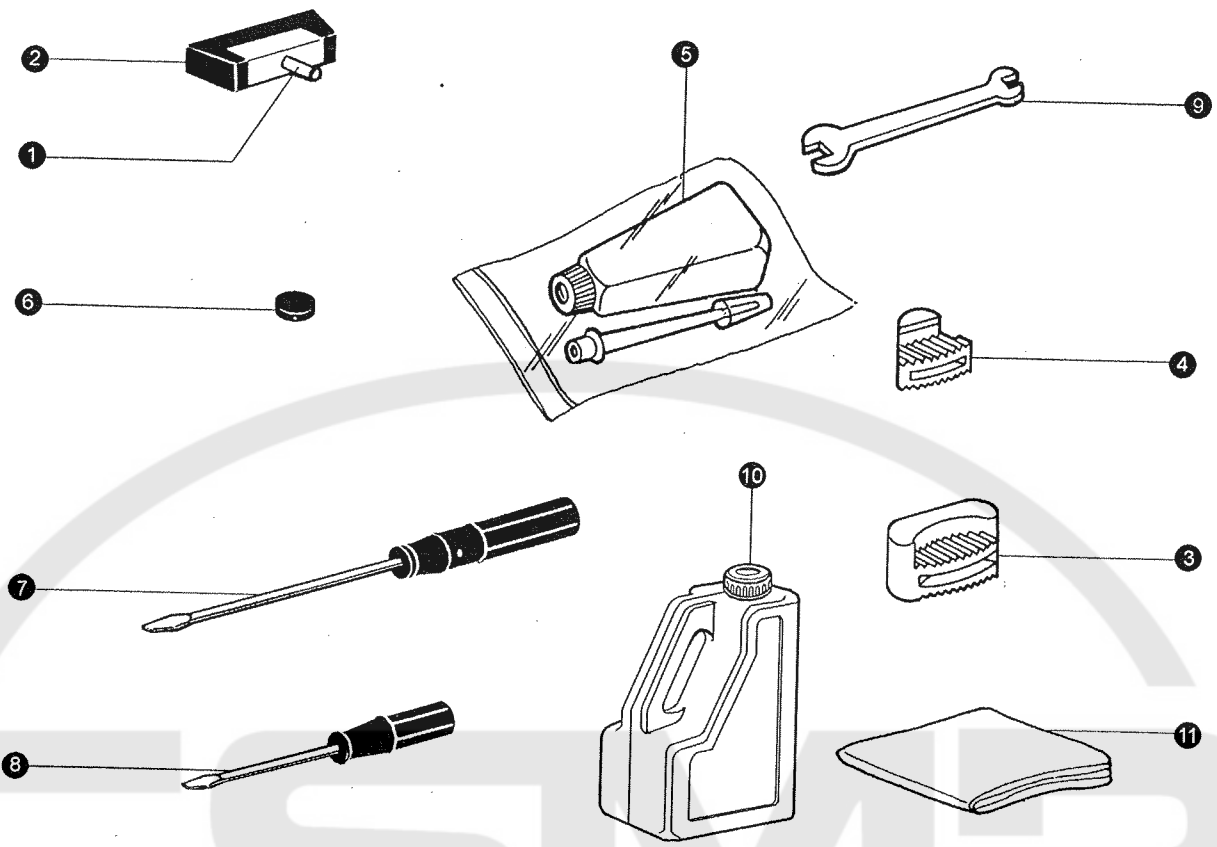

11. ACCESSORIES

No.	Ref. No.	Description	Qt.		
			M	H	B
1	22T9 -007F1	Hinge of machine head			
2	22T9 -007F2	Hinge socket of machine head	2	2	2
3	22T9 -009	Rubber cap(B)	2	2	2
4	22T9 -010	Rubber cap(S)	2	2	2
5	22T9 -011	Oil pot	2	2	2
6	22T9 -012	Magnet	1	1	1
7	22T9 -013	Screw driver(B)	1	1	1
8	22T9 -015	Screw driver(S)	1	1	1
9	22T9 -016	Double end wrench	1	1	1
10	22T9 -017	Oil can	1	1	1
11	22T9 -018	Vinyl cover	1	1	1

**Consolidated Sewing
Machine Corp.**
Website: www.consew.com



MAIN office

131 W. 25th Street
New York, NY 10001
Tel: 212-741-7788
Fax: 212-741-7787
e-mail: consew@att.net

Miami, FL

4013 N.W. 79th Avenue
Miami, FL 33166
Tel: 305-471-0200
Fax: 305-471-0243
e-mail: miamisales@consew.com

Los Angeles, CA

2320 South Hill Street
Los Angeles, CA 90007
Tel: 213-745-8844
Fax: 213-745-8855
e-mail: lasales@consew.com